

# SOUNDSTIK<sup>®</sup> amp

*When you need to keep video kiosk clusters quiet*

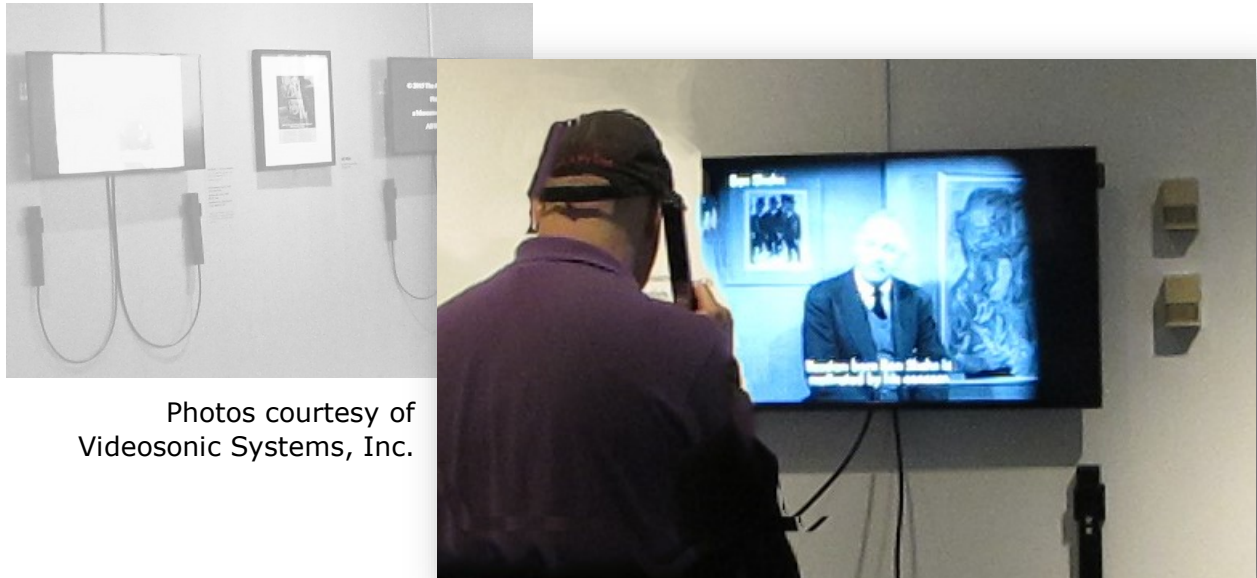

Photos courtesy of  
Videasonic Systems, Inc.

*More immersive. Less noise.*

Silent movies were exciting in their day. Now not so much. Give your visitors great sound and maintain a quiet ambiance. Vista's convenient SoundStik-amp audio handsets are chock-full of features to give long lasting value for the money.

*Visitors lift and listen. Speaker is silent when hanging up.*

- Competing loudspeakers and ambient noise? Increase intelligibility even in noisy environments with personal listening boosted by volume control that automatically resets.
- Are your visitors getting the whole picture? Add audio to provide the other half of the story. Speed comprehension and simultaneously add extra enjoyment and meaning.
- Want to meet disability compliance standards? We can help.

Designed to make the whole work scope easier and better, the SoundStik-amp is an ultra-reliable upgrade for any exhibit with a story to tell.

*We Bring Exhibits to Life*



Woman Owned Small Business SAM Active

25 Van Zant Street, Unit 14-7B, Norwalk, CT 06855

US Toll Free: 1.800.866.2113 TEL: +1.203.852.5557 FAX: +1.203.852.5559

<https://www.vistagroupinternational.com/product-page/soundstik-amp> [info@vistagroupinternational.com](mailto:info@vistagroupinternational.com)



## *Socially Responsible*

- Fulfills ADA and §508 disability access and anti-discrimination regulations
- Eco-friendly materials
- Assembled and serviced in America

# SOUNDSTIK<sup>®</sup> amp

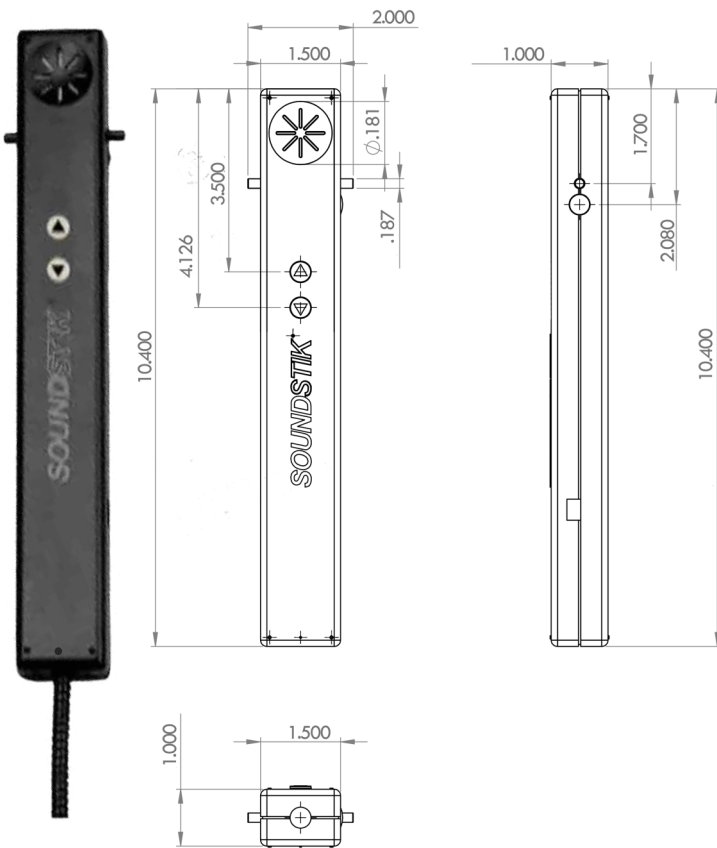

Not to Scale

## FEATURES :

**Convenient** Built-In Amplifier

**Easy** Lift to listen

**Sanitary** Wipes clean

**Highly durable** NoBreak<sup>®</sup> case

**More Capable**

- Client device control contacts
- Auto-mute on hang up
- Adjustable volume while listening with auto-reset to mid-range
- Accessibility compliant

## In the Box:

- SoundStik with built-in amplifier, 48" armored cable with vandal resistant restrainer
- Mounting hardware installed on tether
- Hanger Mount
- Power supply with audio hook-up cable
- Modular junction box with plug and play wiring

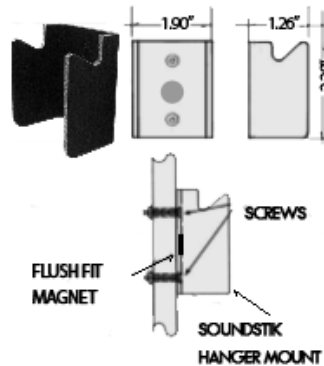

## SPECIFICATIONS

Material	ABS-PC High impact and high stress resistant, flame retardant, eco-friendly, recyclable	Hearing Aid T-Coil Compatible	Yes, ANSI C63. 19-2007**
Size	10.5 L, 1.5 W, 1 D (in) 265 L, 38 W, 27 D (mm)	§ 508 Compliant	Yes
Color	Black	ADA Compliant**	Yes
Push Buttons	Light gray, tactile	ROHS Compliant	Yes
Armored Tether *	Stainless steel, 48" (1220 mm) Black sheathing with stainless steel restrainer cable	Power Supply	Regulated 5VDC 1 Amp
Speaker	32 Ohm, neodymium, PET film	Max Power Consumption	600 Milliwatts
Frequency Response	20Hz-22kHz	Control Switch	Magnetic
SPL	109 db, ±2 db at 1 kHz	Controls	Auto-Reset volume
Volume Adjustment	+/- 15dB Relative to client input	Controls (for optional use)	Auto-Mute on hang up NC condition default NO upon request
Impedance	High	Hanger Mount Material	Aluminum
		Hanger Mount Finish	Black
		Hanger Mount Size	2.38 L, 1.88 W, 1.50" D (in) 57.8 L, 48.5W, 31.9D (mm)
		Modular wiring	6P6C
		Spare Parts	Yes
		Repair Service	Yes
		Warranty	2 Year Limited Lifetime

\*Contact Vista Group for custom lengths

\*\* Contact Vista Group for documentation, if required.