

Serving Great Exhibits Since 1990

LIBERTY IS THE RIGHT AND HOPE OF ALL HUMANITY

...PEOPLE WILL SET THE COURSE OF HISTO

George W. Bush
Presidential Library and Museum
Photo Courtesy:
Design and Production Incorporated

SOUNDSTIK®

We Bring Exhibits To Life

Vista Group International
25 Van Zant Street, Unit 14-7B, Norwalk, CT 06855
Phone: +1 (203) 852 5557, Fax: (203) 852 5559
Toll Free: +1 (800) 866 2113
WOSB, SAM Active
Web: www.vistagroupinternational.com



We Bring Exhibits to Life -

Our clients design, fabricate and maintain stunning exhibits. They deliver education, entertainment and accessibility to thousands, sometimes millions, of visitors.

When they need audio handsets, they need ones that suit various a-v configurations. They want equipment that's cost effective, good looking, reliable and great sounding. We've got that covered and we've added extra value by integrating disability access accommodations as well.

We know what it takes to support exhibits in high profile, high traffic environments. We've been doing it since 1990 for national monuments, parks and visitor centers; for corporate expos and halls of fame; for music museums, science museums and seven Presidential libraries.

Expect us to deliver Value for Money through the entire work scope. SoundStik systems get the job done.

Sincerely,

Martha B. Yaney
Owner/CEO

*Martha Yaney
representing
Connecticut's Small
Business Development
Center at the 35th
Annual Reception of the
America's
Small Business
Development Center on
Capitol Hill*

















SOUNDSTIK® Model Overview

Assembled and serviced in America by Vista Group International, Inc.
 25 Van Zant Street, Unit 14-7B, Norwalk CT 06855
<https://www.Vistagroupinternational.com> info@vistagroupinternational.com
 US Toll Free: 1.800.866.2113 TEL: +1.203.852.5557 FAX: +1.203.852.5559
 WOSB SAM Active



We Bring Exhibits to Life

MODEL	TYPICAL USE	WHAT IT DOES	In the Box
SOUNDSTIK-CLASSIC ADA Compliant  	Brings static exhibits to life 	Plays back audio from any source. Upgrades available: <ul style="list-style-type: none"> • Start/Stop client device • Silence speaker on hang up • 2nd program push button 	Handset with armored cable, strain relief lanyard, heavy duty mounting hardware installed. Junction box for easy hook-up. Hanger Mount
SOUNDSTIK-AMP WITH VOLUME CONTROL  ADA and §508 Compliant 	Quiets video kiosk clusters 	Plays back audio from headphone out or line out. <ul style="list-style-type: none"> • Built-in amplifier • Auto-mute on hang up • Auto-reset volume • Integrated device control contacts 	As above plus: <ul style="list-style-type: none"> • Power supply • Plug and play wiring kit with splitters as required
SOUNDSTIK-MP3 WITH VOLUME CONTROL  ADA and §508 Compliant 	Simplifies self-serve audio tour 	Stores and plays one MP3 file. No player required. <ul style="list-style-type: none"> • Auto-reset volume • Auto-reset program • Easy to change or update audio program 	As above plus: <ul style="list-style-type: none"> • USB cable for file transfer
SOUNDSTIK-VCX  ADA and §508 Compliant 	New tool for adjustable volume with auto-reset 	Companion handset for Vista Group VCX-150: Auto-Reset Volume Amplifier Upgrades available: <ul style="list-style-type: none"> • Reed switch NO or NC • Auto-mute speaker • Hanger Mount 	Handset with speaker, push buttons, armored cable with strain relief. Plug and play hook-up to VCX 150. (VCX 150 purchased separately)
SOUNDSTIK CONSOLE ADA and §508 Compliant  	Takes your show on the road 	Portable multimedia kiosk with many configurations for use with client supplied tablet or graphic panel.	Ready-to-go interactive prefabricated and wired for client selected features.

SOUNDSTIK® classic

For sound without spillover



If you want to install it and forget about it, get a SoundStik. Five years later it will still be working.

Dave Assal
db-mediainc.com

Add audio impact. Reduce noise pollution.

Easy to use, tough to break, backed by over-the-top service. SoundStik-classic handsets give you value for the money.

- Looking for ease of use? Visitors lift to listen.
- Wish it would start the audio program on lift? or turn on an LED? Or silence the speaker when hanging up? We'll build in a switch. How about a push button for a second language?
- Want multiple SoundStik handsets at one source to play until the last one is hung up? You can do it.
- Need easy installation? Works with any sound source. Two wires for audio, two more for a switch. Plug and play wiring or not as you prefer.
- Need low maintenance? Hook up the adjustable length internal restrainer for vandal resistance.

Call Vista Group to discuss your application.

We Bring Exhibits to Life



Woman Owned Small Business SAM Active

25 Van Zant Street, Unit 14-7B, Norwalk, CT 06855

US Toll Free: 1.800.866.2113 TEL: +1.203.852.5557 FAX: +1.203.852.5559

<https://www.vistagroupinternational.com/product-page/soundstik-classic> info@vistagroupinternational.com



Socially Responsible

Fulfills ADA objectives

Eco-friendly materials

Assembled and serviced in America

SoundStik-classic

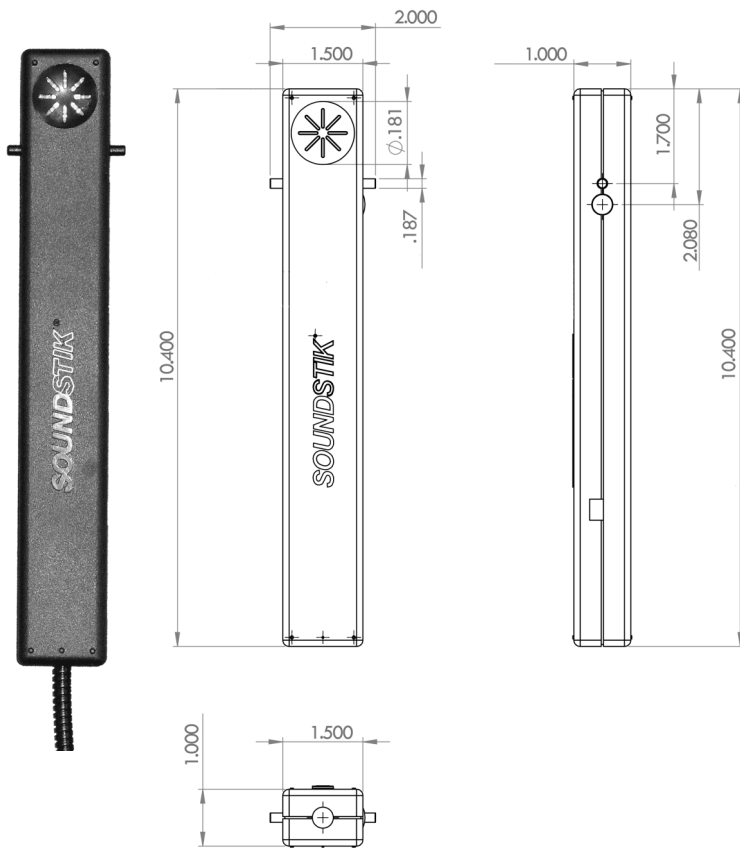

Not to Scale

FEATURES

Easy Lift to listen

Sanitary Wipes clean

Highly Durable NoBreak® case

Versatile Upgrades

- Client device control - Start/Stop/Interrupt
- Auto-mute on hang up - Keeps videos quiet
- On handset push button - 2nd language or message

Available Exhibit Components:

- 2W amplifier for Line Out
- Display panel push buttons
- Message repeaters, etc.

In the Box:

- SoundStik-classic with 48" armored cable with vandal resistant restrainer
- Mounting hardware installed on tether
- Hanger Mount
- Optional 2W amp for Line Out

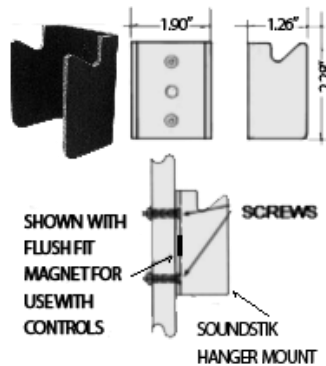

SPECIFICATIONS

Material	ABS-PC	Hearing Aid Compatible	Yes
	High impact and high stress resistant, flame retardant, eco-friendly, recyclable	T-Coil Compatible**	ANSI C63.19-2007
Size	10.5 L, 1.5 W, 1 D (in) 265 L, 38 W, 27 D (mm)	§ 508 Compliant	No
Color	Black	ADA Compliant	Yes
Push Buttons	Light gray, tactile	ROHS Compliant	Yes
Armored Tether *	Stainless steel, 48" (1220 mm), Black sheathing with stainless steel restrainer cable	Control Switch (Available)	Reed
Speaker	32 Ohm, neodymium, PET film	Controls	NC or NO
Frequency Response	20Hz -22kHz	Hanger Mount Material	Aluminum
SPL	109 dB, ±2 dB at 1 kHz	Hanger Mount Finish	Black
Impedance	Low	Hanger Mount Size	2.38 L, 1.88 W, 1.50 D (in) 57.8 L, 1.88 W, 31.9 D (mm)
Audio input	Unbalanced	Spare Parts	Yes
		Repair Service	Yes
		Warranty	2 Year Limited Lifetime

*Contact Vista Group for custom lengths

**Contact Vista Group for documentation, if required.

SOUNDSTIK[®] amp

When you need to keep video kiosk clusters quiet

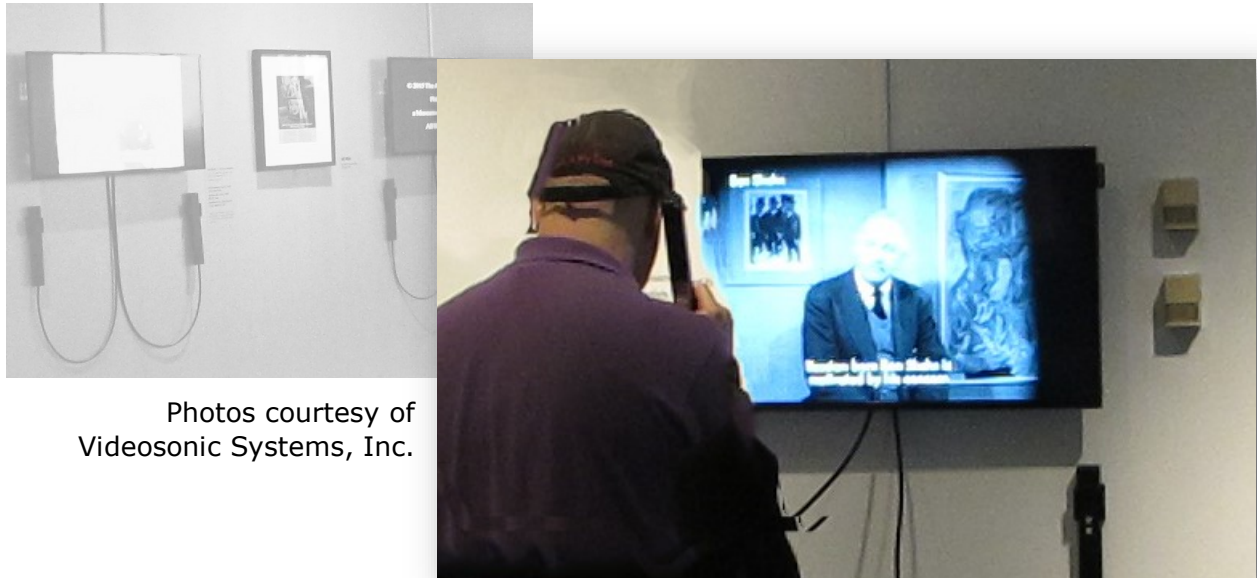

Photos courtesy of
Videasonic Systems, Inc.

More immersive. Less noise.

Silent movies were exciting in their day. Now not so much. Give your visitors great sound and maintain a quiet ambiance. Vista's convenient SoundStik-amp audio handsets are chock-full of features to give long lasting value for the money.

Visitors lift and listen. Speaker is silent when hanging up.

- Competing loudspeakers and ambient noise? Increase intelligibility even in noisy environments with personal listening boosted by volume control that automatically resets.
- Are your visitors getting the whole picture? Add audio to provide the other half of the story. Speed comprehension and simultaneously add extra enjoyment and meaning.
- Want to meet disability compliance standards? We can help.

Designed to make the whole work scope easier and better, the SoundStik-amp is an ultra-reliable upgrade for any exhibit with a story to tell.

We Bring Exhibits to Life



Woman Owned Small Business SAM Active

25 Van Zant Street, Unit 14-7B, Norwalk, CT 06855

US Toll Free: 1.800.866.2113 TEL: +1.203.852.5557 FAX: +1.203.852.5559

<https://www.vistagroupinternational.com/product-page/soundstik-amp> info@vistagroupinternational.com



Socially Responsible

- Fulfills ADA and §508 disability access and anti-discrimination regulations
- Eco-friendly materials
- Assembled and serviced in America

SOUNDSTIK[®] amp

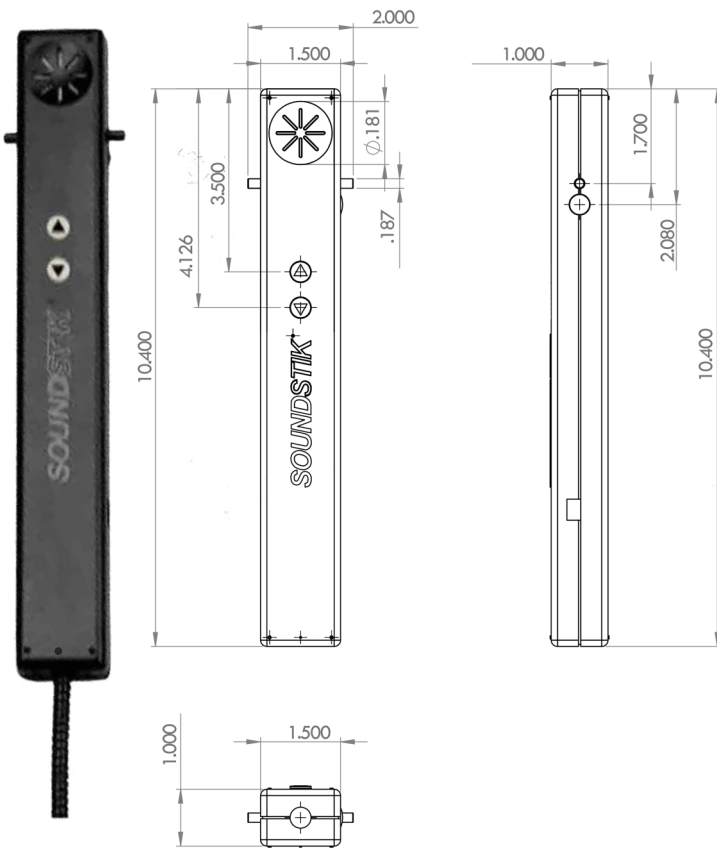

Not to Scale

FEATURES :

Convenient Built-In Amplifier

Easy Lift to listen

Sanitary Wipes clean

Highly durable NoBreak[®] case

More Capable

- Client device control contacts
- Auto-mute on hang up
- Adjustable volume while listening with auto-reset to mid-range
- Accessibility compliant

In the Box:

- SoundStik with built-in amplifier, 48" armored cable with vandal resistant restrainer
- Mounting hardware installed on tether
- Hanger Mount
- Power supply with audio hook-up cable
- Modular junction box with plug and play wiring

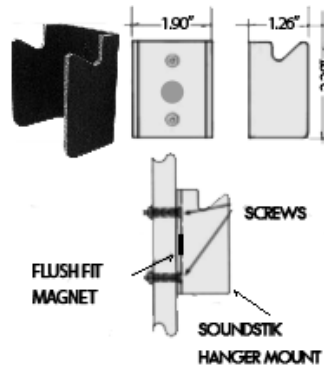

SPECIFICATIONS

Material	ABS-PC High impact and high stress resistant, flame retardant, eco-friendly, recyclable	Hearing Aid T-Coil Compatible	Yes, ANSI C63. 19-2007**
Size	10.5 L, 1.5 W, 1 D (in) 265 L, 38 W, 27 D (mm)	§ 508 Compliant	Yes
Color	Black	ADA Compliant**	Yes
Push Buttons	Light gray, tactile	ROHS Compliant	Yes
Armored Tether *	Stainless steel, 48" (1220 mm) Black sheathing with stainless steel restrainer cable	Power Supply	Regulated 5VDC 1 Amp
Speaker	32 Ohm, neodymium, PET film	Max Power Consumption	600 Milliwatts
Frequency Response	20Hz-22kHz	Control Switch	Magnetic
SPL	109 db, ±2 db at 1 kHz	Controls	Auto-Reset volume
Volume Adjustment	+/- 15dB Relative to client input	Controls (for optional use)	Auto-Mute on hang up NC condition default NO upon request
Impedance	High	Hanger Mount Material	Aluminum
		Hanger Mount Finish	Black
		Hanger Mount Size	2.38 L, 1.88 W, 1.50" D (in) 57.8 L, 48.5W, 31.9D (mm)
		Modular wiring	6P6C
		Spare Parts	Yes
		Repair Service	Yes
		Warranty	2 Year Limited Lifetime

*Contact Vista Group for custom lengths

** Contact Vista Group for documentation, if required.

SOUNDSTIK® mp3

For audio impact with less to buy and hide



...we have been thrilled with their performance! Visitor feedback has been great – so we are looking to add some more Stiks in the museum.

*Justin Gamache
Wright Museum of World War II*

Photo Courtesy of the Wright Museum of WWII

A self-contained sound system

Fortify your exhibit with CD quality sound and disability access compliance by using a convenient SoundStik-mp3 audio handset.

Visitors lift and listen. Program starts automatically.

- So much to see? Bring out the best with a highlight tour and simultaneously accommodate visitors who have low-vision.
- Static exhibit? Give it energy with character voices, music and sound effects.
- Visitors ignoring your text panels? Expand your reach to visitors who are expecting multimedia.
- Competing with ambient noise? Increase intelligibility and reduce noise pollution with personal listening. Adjustable volume helps visitors who are hard-of-hearing and it resets automatically for the next user.

An all-in-one solution for exhibit interpretation, the SoundStik-mp3 is designed for simplicity and reliability from start to finish.

Contact us to discuss your application.

We Bring Exhibits to Life



Woman Owned Small Business SAM Active

25 Van Zant Street, Unit 14-7B, Norwalk, CT 06855

US Toll Free: 1.800.866.2113 TEL: +1.203.852.5557 FAX: +1.203.852.5559

<https://www.vistagroupinternational.com/product-page/soundstik-mp3> info@vistagroupinternational.com



Socially Responsible

- Fulfills ADA and §508 disability access and anti-discrimination regulations
- Eco-friendly materials
- Assembled and serviced in America

SoundStik-mp3

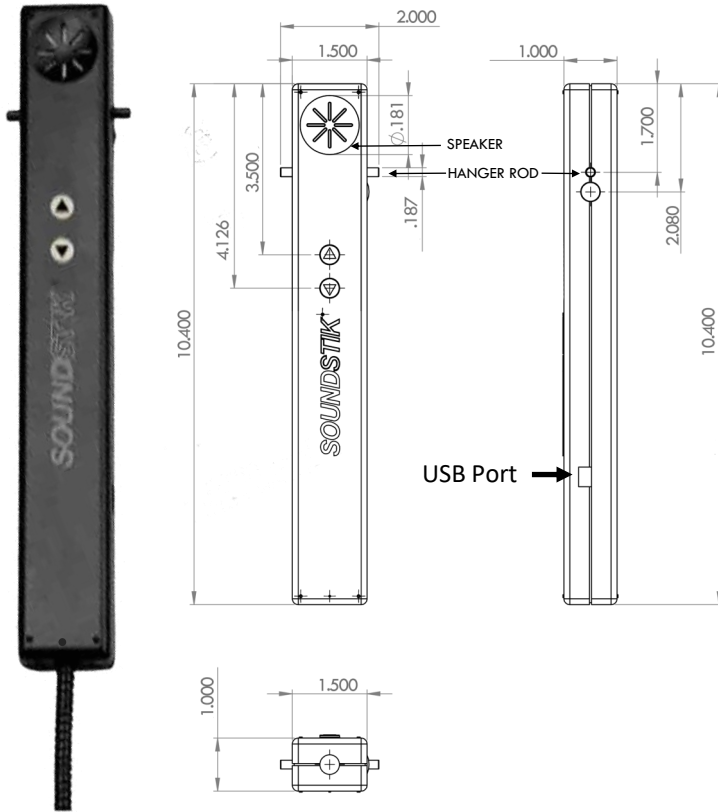

Not to Scale

FEATURES

Stores and Plays an MP3 File

No player required

Lift and Listen

Program starts automatically

Volume is adjustable and resets

Low Maintenance

Easy to update mp3 file: USB/SD

Sanitary - Wipes clean

Highly durable *NoBreak*® Case

In the Box:

- SoundStik-mp3 with 48" armored cable with vandal resistant restrainer
- Mounting hardware installed on tether
- Hanger Mount
- Power supply
- USB cable
- Plug-and-play wiring.

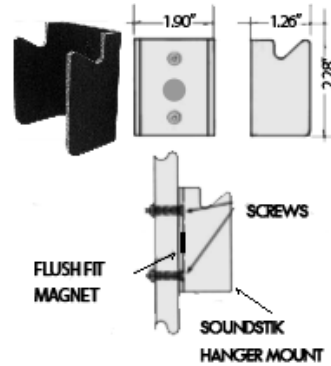

SPECIFICATIONS

Material	ABS-PC High impact and high stress resistant flame retardant, eco-friendly, recyclable	Hearing aid T-coil compatible	Yes, ANSI C63.19-2007**
Size	10.5 L, 1.5 W, 1 D (in) 265 L, 38 W, 27 D (mm)	§ 508 compliant	Yes
Color	Black	ADA compliant	Yes
Push Buttons	Light gray, tactile	ROHS compliant	Yes
Armored Tether *	Stainless steel, 48" (1220 mm), black sheathing with stainless steel restrainer cable	Power Supply - switching	5VDC Regulated, 1 Amp
Speaker	32 Ohm, neodymium, PET film	Max power consumption	600 Milliwatts
Frequency Response	20Hz-20 kHz	Control switch	Magnetic
SPL	109 dB, ±2 dB at 1 kHz	Controls	Start on pick-up, Auto-reset volume
Volume Adjustment	+/- 15db Relative to client input	Hanger Mount Material	Aluminum
Capacity	256 Minutes CD quality sound	Hanger Mount Finish	Back
Bit Rate	128 kbps	Hanger Mount Size	2.38 L, 1.88 W, 1.50 D (in) 57.8 L, 48.5 W, 31.9 D (mm)
Sampling Frequency	44.1 kHz	Spare Parts	Yes
		Repair Service	Yes
		Warranty	2 Year Limited Lifetime

* Contact Vista Group for custom lengths

** Contact Vista Group for documentation, if required.

SOUNDSTIK® vcx

For VCX150 Auto-Reset Volume Amplifier

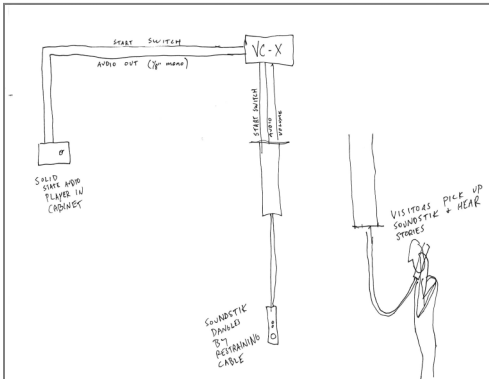

PNC Bank Legacy Project, Pittsburgh
Design, Media and Fabrication by
Quatrefoil Associates

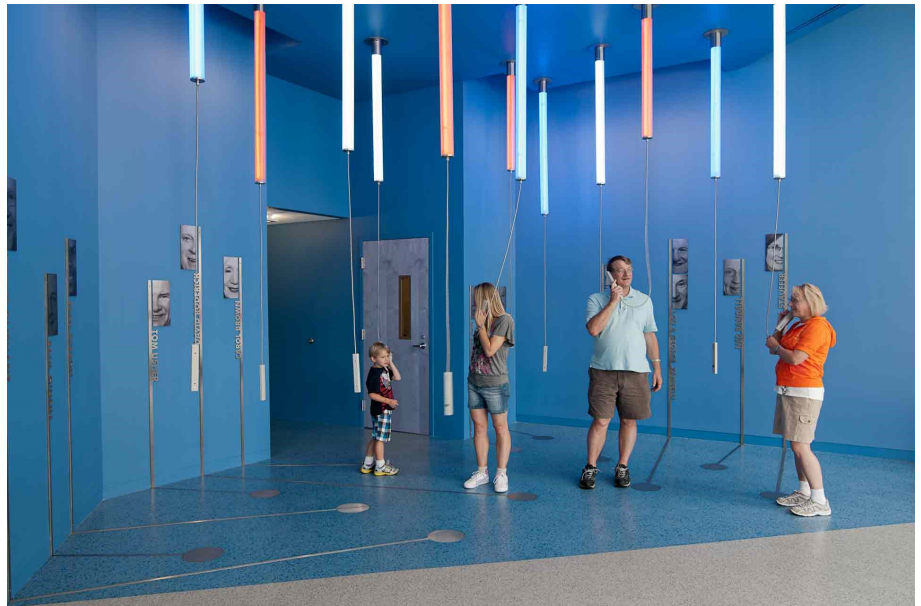

Offering 6 new solutions for listener adjustable volume with auto-reset

The SOUNDSTIKvcx is a companion audio handset for Vista Group's external volume resetting amplifier. The combination gives audio-visual designers new tools for offering personalized audio at exhibits, kiosks, and interactive displays. In addition, it helps exhibits comply with accessibility regulations.

Visitors lift the SOUNDSTIKvcx handset and start playback of the soundtrack or audio program. They can adjust volume to their preferred level while listening. The VCX150 will hold the volume until the visitor finishes listening. Then it resets.

Available options: Hanger Mount, remote audio jack, client device control switch.

Call us to find out more.

We Bring Exhibits to Life



VCX 150 Modes

- 1) Typical push button start
- 2) Invert
- 3) Follow
- 4) Silence detect
- 5) Mute on Hang Up
- 6) Earphone Detect



Woman Owned Small Business SAM Active

25 Van Zant Street, Unit 14-7B, Norwalk, CT 06855

US Toll Free: 1.800.866.2113 TEL: +1.203.852.5557 FAX: +1.203.852.5559

<https://www.vistagroupinternational.com/product-page/soundstik-vcx> info@vistagroupinternational.com



SOUNDSTIK® *Portable Consoles*

All-In-One Kiosks: Performance and Reliability

With a SoundStik Console, you will have the freedom to offer an interactive display anywhere you want. Use it in your entryway to welcome visitors. Present interviews with board members to encourage donations and memberships. Lend it to the library or nature center as a table top travelling exhibit and promote your events.



Versatile configurations. Industrial strength. Easy to clean. Helps visitors who have low vision or who are hard-of-hearing. Engineered and assembled in America.



SOUNDSTIK iPad Console

Load your video onto the iPad and let the soundtrack play. SoundStik handsets are silent when hanging up and play on lift. Built-in loudspeakers for a classroom group.

Great for looping videos.



SOUNDSTIK-mp3 Console

Mount your graphic, photo, or brochure holders on the panel. Copy your mp3 file to our handsets by USB/SD. You're ready to go.

Ideal for frequently changing messages.

*AVAILABLE OPTIONS INCLUDE: Donor nameplates • Earphone jack for BYOD headphones. • Mini public address system
Braille plates • Language labels. FINISHES: natural cherry, cherry sorrel, custom*

DIMENSIONS: Front Panel: 22" x 15" panel, Console: 10"H, 22"W, 15.5"D" **WEIGHT:** 23 pounds

Give us a call to talk about your application

We Bring Exhibits to Life

Vista Group International, Inc.

Woman Owned Small Business SAM Active

25 Van Zant Street, Unit 14-7B, Norwalk, CT 06855

TEL: +1 203.852.5557 FAX +1 203.852.5559

VistaGroupInternational.com info@vistagroupinternational.com



Exhibit Audio

We bring exhibits to life



VISTA GROUP INTERNATIONAL, INC.

Capability Statement

Core Competencies

Vista Group International provides interpretive audio for curators, exhibit designers and builders. We service, sell and manufacture **SOUNDSTIK® audio handsets** and interactive **iPad Consoles**, **VCX Volume Auto-Reset amplifiers**, and **SoundPost outdoor audio signs**. Vista Group also offers digital message repeaters, tour guide systems, self-guided audio tour tablets and apps; and we support clients with a wide range of program content services.

Past Performance

References Upon Request

SOUNDSTIK®

- National September 11 Memorial & Museum
- J. F. Kennedy Center for Performing Arts
- Seven Presidential Libraries
- National Pro Football Hall of Fame
- National Center for Civil & Human Rights
- White House Visitor Center

VCX Volume Auto-Reset Amp

- White House Visitor Center
- National September 11 Memorial & Museum
- PNC Bank, Pittsburgh, PA
- Central High School, Little Rock, AR

Tour Guide Systems

- Stanford University Travel Study Program
- TCS and Starquest Expeditions
- Novitex

SoundPost

- Florida Dept. of Environment—mains
- Sentinel Rock State Park, VT—battery
- Mattie Stepanek Peace Park, MD—solar

SoundStik iPad Console

- New City Library, NY
- Darien Historical Society, CT

Differentiators

Value for Money

We design our products to be rock-solid for long-term public use and abuse. Easy to install. Easy to use. SoundStik cases are eco-friendly as well as high impact resistant, high stress resistant and fire resistant. Vista Group service and parts prevent waste; and we back up our work with the longest warranties in the business.

Only Audio Handset to Meet Accessibility Regulations

SoundStik models meet ANSI/EEE Std. C63.19-2007 HAC, ADA, and Section 508 standards.

Ralph Appelbaum Inspired SoundStik® Case

Simple architectural lines—stylish, but unobtrusive. Designed and manufactured specifically for museums and tourist attractions. Custom colors, text or logo etching available.

Versatile

Broader choice of features to suit your needs. Custom systems. Content development, editing, production or translation.

Tops in Service

Our client list tells the story. Friendly, knowledgeable support from start to finish. We do what it takes to assure our products merit your trust.

US-Based Manufacturer

Our proprietary products are designed, engineered, assembled, programmed and serviced in America from US and globally sourced components.

Martha Yaney is a co-founder of Vista Group International and has been owner and president since 2011. She is a Connecticut Council of Technology “Women of Innovation®” 2015 Honoree.



25 Van Zant Street, Unit 14-7B
Norwalk, CT 06855
VistaGroupInternational.com
TEL: 203.852.5557
FAX: 203.852.5559



Contact: Martha B. Yaney, Owner/President
martha.yaney@vistagroupinternational.com

Pertinent Codes

Duns: 626596688 WOSB SAM Active CAGE Code: 5LLM5
NAICS: 334310 Primary, 334290, 335999, 339950, 423690, 512290
PSC: 5996, 5965, 5835
Payment Terms: Accept bank checks, EFT, credit cards and purchase cards



- Museums
- Visitor Centers
- Historic Sites
- Parks
- Libraries
- Nature Centers
- Halls of Fame
- Corporate Exhibits

4 MORE WAYS TO BRING EXHIBITS TO LIFE

Just tell us what you want your visitors to experience. We can help you short cut the maze of alternatives and provide a wide range of content services.

1 Personalize kiosk listening experiences

Add volume control with auto-reset for BYOD headphones or low power speakers by using our VCX-150 amplifier. Plugging in headphones can start a program.



2 Guide group tours like the pros

You've trained the docents, but if visitors can't hear, their tour will be disappointing. Tour guide systems work like micro radio stations. Guides can speak in normal tones, even softly.

3 Keep in touch with apps

Adding a mobile app to your offerings can generate new visits and create extended connections to your visitors. Museum audio tours, GPS tours, bus tours, e-commerce, ticketing and more.

4 Tell your story rain or shine

When you can't staff outside exhibits, our SoundPost audio signs can be your story tellers. Powered by mains, batteries or solar cells.

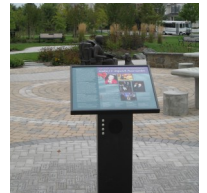

Call us to discuss your application

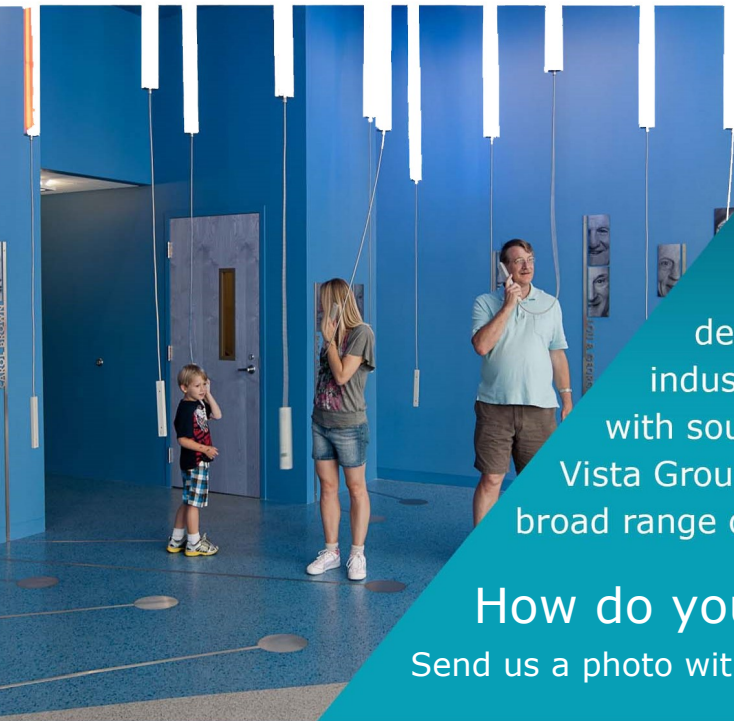

Vista Group International

Vista Group International works with exhibit designers in the museum, trade-show and tourism industries who are seeking to enhance their exhibits with sound. We bring exhibits to life. Established in 1990, Vista Group is a Woman Owned Small Business providing a broad range of exhibit audio devices and interactive systems.

How do you SoundStik your story?

Send us a photo with your caption and credits.